

KEEPING PERSONNEL AND EQUIPMENT SAFE FOR

**35 YEARS**



# ATMOSPHERIC OIL MIST DETECTION SYSTEM



## ATMOSPHERIC OIL MIST DETECTION SYSTEM



The QMI Atmospheric Oil Mist Detection System is used to identify oil mist in confined areas such as: engine rooms, pump rooms, bow thrusters, purifier rooms, hydraulic pack areas and test cells.

**The equipment uses light scatter (nephelometry) technology. This allows the system to:**

- ✓ Deliver rapid response within 500 milliseconds of oil mist being detected
- ✓ Measure oil mist particles between 3 and 10 microns
- ✓ Quantify oil mist in mg/L
- ✓ Activate a relay when oil mist is detected

The Atmospheric Sensors are used with QMI Multiplex (12 channel) or QMI Triplex (3 channel) Monitors. The number of Sensors required, will depend on the size of the space being monitored. The atmospheric sample is drawn through the front louvre by the integral fan, through the measuring chamber, then exhausted out of the back of the Sensor.

The Multiplex & Triplex Monitors incorporate a 'traffic light' system on each channel to ensure that operators know at first glance if there are hazardous concentrations of oil mist.

### KEY FEATURES

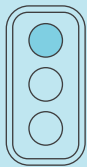

Traffic light system to easily identify an issue



Tamper proof once alarm levels set



Self-Diagnostic system detects faults or dirty Sensor



Older models are fully upgradable

The Monitor indicates oil mist levels as a percentage of the set alarm limit.  
The Monitor can be set to read **100% at 1.3 mg/L and 2.00 mg/L.**

For atmospheric applications, we would advise to set the alarm limit at **100% for 0.05 mg/L** to ensure the earliest indication of an oil mist release.

Early detection of oil mist helps to safeguard personnel and equipment before a fire occurs. An oil mist release of any size must be treated as a potential fire risk.

**An Atmospheric Oil Mist Detection System for up to 12 channels, typically contains the following:**

Description	Product Code
1 x Multiplex Monitor with Harting Connectors	Q01H
1 x Junction Box	Q07
Atmospheric Sensor*	Q10C
Atmospheric Sensor Maintenance Kit	Q1005

**An Atmospheric Oil Mist Detection System for up to 3 channels, typically contains the following:**

Description	Product Code
1 x Triplex Monitor with Individual Shutdown	Q01T
1 x 3 Way PCB	Q01T06
Atmospheric Sensor*	Q10C
Atmospheric Sensor Maintenance Kit	Q1005

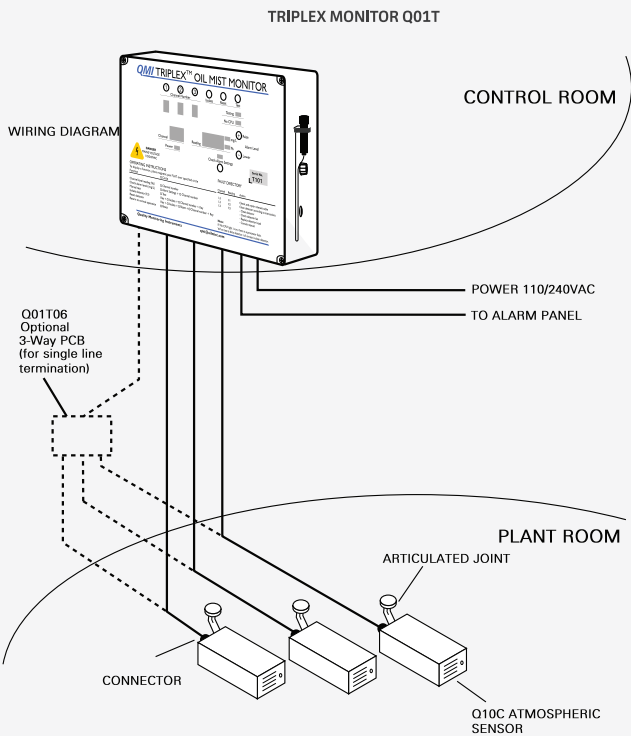
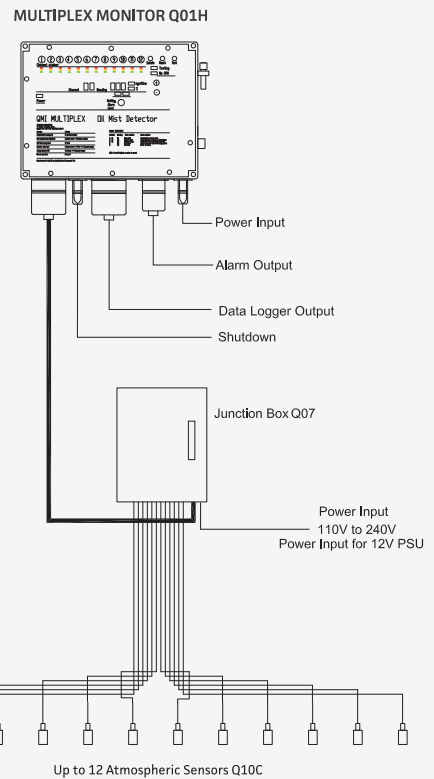

**Optional extras include:**

- Data Logger output
- Modbus output
- Individual or grouped shutdowns (Multiplex only)

\* The number required depends on the size of the space being monitored, taking into account the ventilation in this space and the number of potential leakage sources.

**WHY CHOOSE A QMI ATMOSPHERIC OIL MIST DETECTION SYSTEM?**

- ✓ More than 35 years experience of keeping machine rooms safe
- ✓ Manufactured in the United Kingdom to ISO 9001:2015 Standards
- ✓ Provides fast indications of low levels of oil mist in enclosed spaces
- ✓ Type approved by Lloyds Register and the American Bureau of Shipping
- ✓ Conforms to ISO standard 16437:2012





Product Code: **Q01H**

## MULTIPLEX MONITOR OVERVIEW

- ✓ For use with between 1 – 12 Sensors
- ✓ Clear traffic light display of oil mist level on each channel
- ✓ Self test program for Monitor, Sensor and wiring
- ✓ Tamper proof key protection
- ✓ Cast aluminum hinged enclosure sealed to IP65
- ✓ Operated with magnetic Hall effect switches
- ✓ Operating instructions & fault directory on faceplate
- ✓ Hinged access panel
- ✓ Harting Connectors

## TECHNICAL SPECIFICATIONS

<b>Power Supply</b>	Nominal 110V - 240VAC 50/60Hz
<b>Power Consumption</b>	100W
<b>Sampling Channels</b>	12
<b>Response Time</b>	500 milliseconds

<b>Alarm Relays</b>	Main Alarm
	Fault Alarm
	Shutdown Alarm
<b>Dimensions</b>	403mm x 312mm x 128mm
<b>Unit Weight</b>	10kg



Product Code: **Q01T**

## TRIPLEX MONITOR OVERVIEW

- ✓ For use with between 1 – 3 Sensors
- ✓ Clear traffic light display of oil mist level on each channel
- ✓ Self test program for Monitor, Sensor and wiring
- ✓ Tamper proof key protection
- ✓ Cast aluminium hinged enclosure sealed to IP65
- ✓ Operation by magnetic Hall effect switches
- ✓ Operating instructions & fault directory on faceplate
- ✓ Hinged access panel
- ✓ Blind grommets sealing cable access to Monitor connections

## TECHNICAL SPECIFICATIONS

<b>Power Supply</b>	Nominal 110V - 240VAC 50/60Hz
<b>Power Consumption</b>	100W
<b>Sampling Channels</b>	3
<b>Response Time</b>	500 milliseconds

<b>Alarm Relays</b>	Main Alarm
	Fault Alarm
	Shutdown Alarm
<b>Dimensions</b>	280mm x 230mm x 128mm
<b>Unit Weight</b>	5.2kg



Product Code: **Q10C**

## ATMOSPHERIC SENSOR

- ✓ Manufactured from cast aluminium
- ✓ Easily replaceable integral fan
- ✓ LED on front of Sensor to indicate operation and fan status
- ✓ Stainless steel articulated joint for mounting and directional orientation
- ✓ Sealed to IP65
- ✓ Factory calibrated

## TECHNICAL SPECIFICATIONS

<b>Dimensions</b>	359mm x 113mm x 73mm
<b>Unit Weight</b>	2.3kg

## JUNCTION BOX (FOR MULTIPLEX)

- ✓ Provides power for the integral fan for up to 12 Sensors
- ✓ Contains PCB with PSU for connection of Sensors
- ✓ Cable glands for Sensor cable access
- ✓ Metal enclosure with hinged access

## TECHNICAL SPECIFICATIONS

<b>Dimensions</b>	300mm x 400mm x 160mm
<b>Unit Weight</b>	6.72kg



Product Code: **Q07**

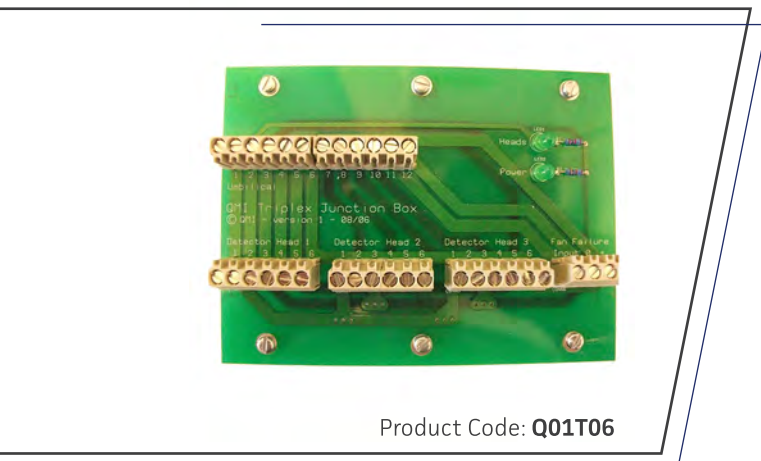

Product Code: **Q01T06**

## PCB (FOR TRIPLEX)

- ✓ For up to 3 Atmospheric Sensors
- ✓ Allows single penetration through bulkhead

## TECHNICAL SPECIFICATIONS

<b>Dimensions</b>	100mm x 135mm x 25mm
-------------------	----------------------